

Piano

LIFE SAVER SYSTEM®

from
DAMPP-CHASER



VERTICAL 5-PART SYSTEM INSTALLATION INSTRUCTIONS

TOOLS REQUIRED: This System includes 1/4" hexhead screws. To install the System, you will need:

- ratcheting driver
- cordless drill
- small blade screwdriver
- wirecutters
- screw starter
- small hammer
- chalk or other marker
- scissors
- file
- measuring tape

The following is a list of components:

		Purpose
1	48-inch Dehumidifier (with attached extensions)	Removes excess moisture from the piano
1	Humidistat	Controls the Humidifier and Dehumidifier
1	Humidifier	Brings moisture into the piano
1	Water Sensor Probes	Measure water depth in Humidifier
1	Humidifier Heater Bar	Warms pads to aid evaporation
1	Two-light Panel	Shows System is energized and when to add water
1	Watering tube	Enables the delivery of water to the Humidifier
1	Humidifier pads	Used to vaporize moisture from the Humidifier
1	Moisture Distribution Baffle	Dispenses moisture throughout the piano
1	Watering Can	For adding water to the Humidifier
1	Third Hand Template	Assists with Dehumidifier installation
1	Bottle of Humidifier Treatment	Additive that prolongs the life of the pads
1	Hardware kit	Described below
1	System Care and Maintenance sheet / 5-Year Warranty Certificate	

The hardware kit includes the following:

2	Y Hangers	Used to suspend the Humidifier tank when necessary
13	1/2-inch #8 screws	Mounts clamps
2	3/4-inch #8 screws	Used to attach the light panel
3	3/16-inch clamps	Attaches wire between light panel and Humidistat
2	1/2-inch standard clamps	Attaches watering tube between keybed and Humidifier
2	Half clamps and serrated washers	Attaches the end of the watering tube to the rim
6	1/4-inch clamps	Anchors Humidistat power cord wire
2	Screw hooks	Used to suspend the Humidifier when necessary. Used with Y Hangers
2	Wire ties and cable ties	Used to bundle excess cords
4	Pin pegs	Used to mount Dehumidifier and the Moisture Distribution Baffle
2	Plastic hanger C clips	Used to mount the Humidistat on the Dehumidifier
1	Warranty Registration card	

Optional Smart Bracket package includes:

Smart Bracket Sensors	Attaches to Humidifier heater bar and senses when pads are dry
Single-Light Cube	Signals when Humidifier pads are dry

While we make every effort to ensure that all components are included, it is a good idea to check that none are missing prior to arriving at the installation location. In the unlikely event that a part is missing, please call toll-free 800-438-1524 with information from the end of the box and the assembler's name. We will provide same-day shipment of the replacement part.

To the Piano Technician Installer

CAUTION

You are responsible for making a proper System installation by carefully following these instructions.

PLEASE PAY STRICT ATTENTION TO THE FOLLOWING ISSUES:

- 1) The vertical piano can be exposed to excessive condensation from the Humidifier if the baffle is not installed.
- 2) If a cord/wire in the System is installed in direct contact with a Dehumidifier heating rod, over time, the cord/wire could dry out and crack, posing a fire or shock hazard. Carefully anchor cords/wires away from the Dehumidifiers with the ties and clamps provided with the System.
- 3) Do not use a Dehumidifier in the action of the piano without a Humidistat to control it. To dehumidify the action, we recommend you install a 36-inch, 25 watt Dehumidifier outside the case, under the keybed, and plug this Dehumidifier into the System's Humidistat.
- 4) Advise your clients that they should only use the Damp-Chaser brand of Humidifier Treatment in the Humidifier. Other brands of humidifier treatment may contain acids which can corrode strings and metal parts in the piano. Use of another brand of treatment voids the System's warranty and may also void the piano manufacturer's warranty.

OTHER IMPORTANT INFORMATION

- 1) The newly-installed Piano Life Saver System will alter the piano's wood-moisture content and, therefore, alter the tuning. Ideally, the System should be installed 3 weeks BEFORE the piano is tuned.
- 2) A frayed or cracked electrical cord/wire can cause a fire or shock. If the piano runs over the power cord it can be damaged. Please inspect the System's cords/wires each time you service the piano. See page 8 for information about the Fused Plug on the Humidistat power cord.
- 3) Installation of the Piano Life Saver System must be made by a professional Piano Technician or Tuner. Any warranties stated or otherwise implied are void if the installation is made by someone other than a professional Piano Technician or Tuner.

Warranty Service Call Policy: The 5-Year Warranty for this System covers parts only. Damp-Chaser Corp. assumes no responsibility for piano technician labor in maintenance, repair or warranty service calls related to the Piano Life Saver System. When Systems are priced according to the manufacturer's guidelines, most installers agree there is sufficient compensation to cover a possible warranty service call. At the time you install the System, please explain any post-installation fees to the System owner.



DAMPP-CHASER CORPORATION

Toll-free: 800-438-1524 • 828-692-8271 • Fax: 828-692-8272
www.PianoLifeSaver.com • e-mail: piano@damp-chaser.com
Post Office Box 1610 • Hendersonville, North Carolina 28793

STEP 1. HUMIDIFIER INSTALLATION

You should install the Humidifier first. When you unpack the System box, you will find several items in the Humidifier tank: Humidifier pads, the two-light panel, and the watering tube. Remove the light panel and pads for later use. Uncoil the watering tube and leave it outside the tank. Make sure the end of the tube is within the plastic liner inside the tank. Please note the Water Sensor probes and Humidifier heater bar are attached to the Humidifier at the factory. The Water Sensor probes are attached to the Humidifier heater bar mounting bracket at the middle of the Humidifier (**Figure 1**).

The Humidifier pads are designed to wick water over the heater bar, producing warm moist air currents which rise and are circulated throughout the piano. If you have ordered the optional Smart Bracket (SB) with this System, the bracket sensors will signal via a red light when the pads no longer wick water and require replacement. The Smart Bracket also turns off the

Humidifier heater bar when the pads fail or when the Humidifier runs out of water.

Mounting the Smart Bracket: Open the SB package and take out the SB sensors (with attached C clips) and the red SB single-light cube. Put aside the light for later. To attach the sensors to the heater bar, slide the C clips on the SB sensors into the positions shown in **Figure 2** and press firmly downward. The sensors on the SB should lie on the top of the heater bar.

Drape the Humidifier pads across the heater bar and push them down into the tank as shown in **Figure 1**. If necessary, adjust the C clips on the SB sensors to insure the pads are in direct contact with the sensors. Unbundle the cords from the SB, the Water Sensor probes and the Humidifier heater bar.

Remove the bottom panel of the piano and put the Humidifier tank on the floor in the bottom corner of the treble or bass end (**Figure 3**). Place the tank in the side where the trapwork does not interfere.

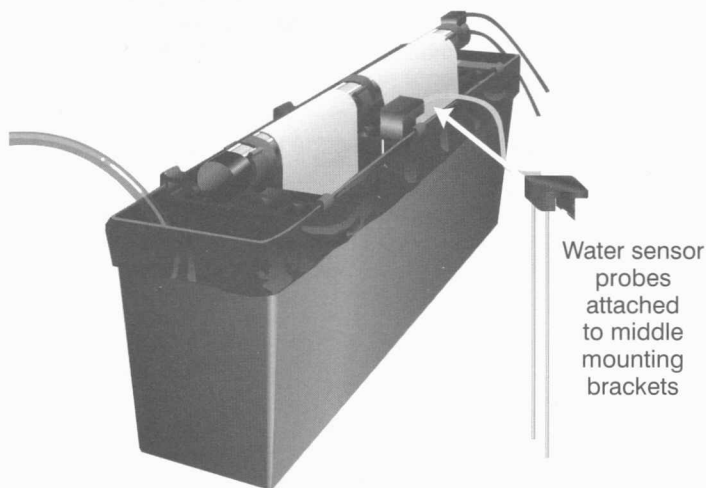

FIGURE 1
Humidifier with pads installed

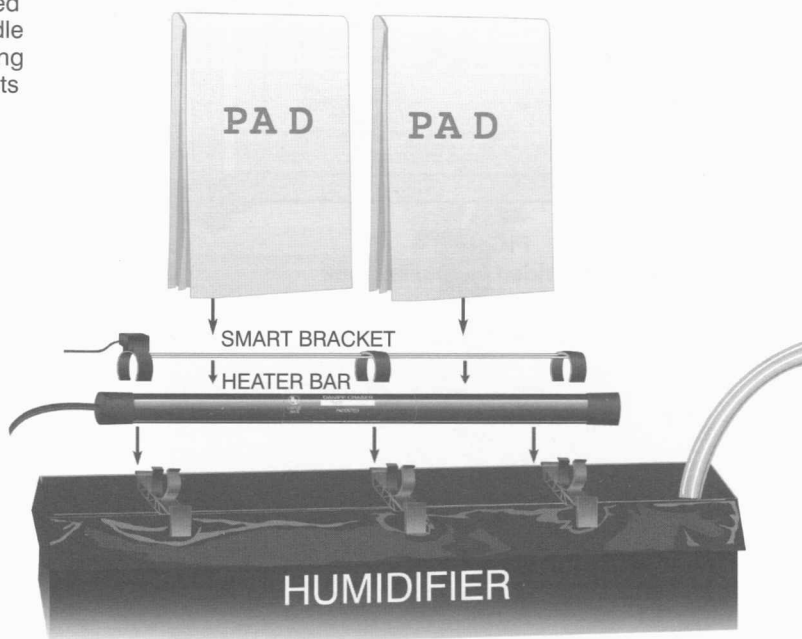

FIGURE 2

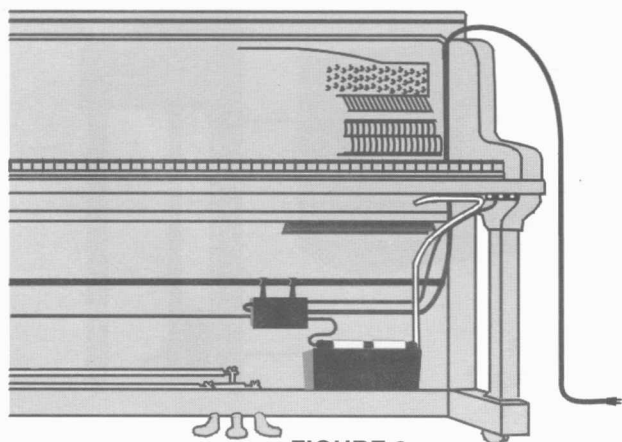

FIGURE 3
Humidifier placement

STEP 1-A. SUSPENDING THE HUMIDIFIER TANK ABOVE TRAPWORK

In some pianos, the trapwork prevents placing the Humidifier tank in the bottom, and you will need to suspend the tank above the trapwork (**Figure 4**).

When the position of the tank has been determined, center the Moisture Distribution Baffle over the tank position. Then, mount the Baffle according to the instructions in STEP 2.

Y hangers and screw hooks are used to suspend the tank (**Figure 5**). First, attach the Y hangers to the inside of the tank using the screws at the four corners of the tank. Loosen the screws which are already on the tank. These screws do not require wing nuts to secure them because they are self-locking and will not loosen. If necessary, enlarge the holes in the liner to drive the screws in.

Screw the hooks through the Baffle about 14 inches apart. Hang the Humidifier as low as possible above the trapwork. To achieve the proper height for the tank, it may be necessary to cut the Y hangers' top legs with your wire cutters. Note that the Dehumidifier will be installed approximately 8 inches above the Humidifier.

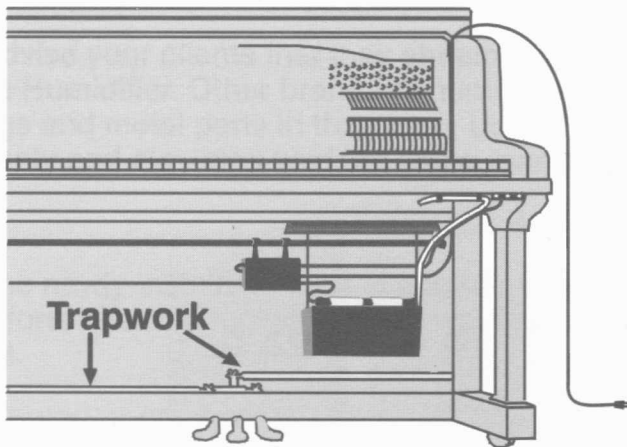

FIGURE 4
Suspended Humidifier tank

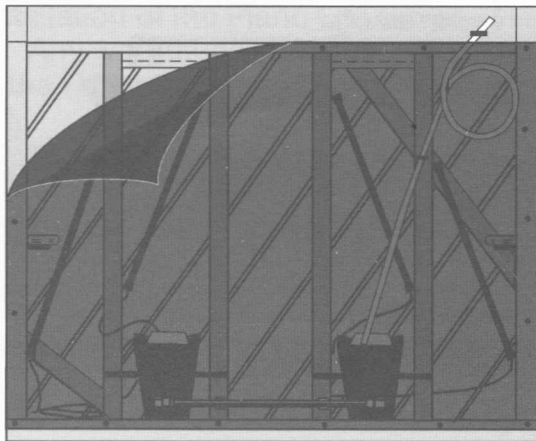

FIGURE 6
Backside Vertical 9-Part System



FIGURE 8
Baffle affixed to keybed with pin pegs

Use of Backside System

The Universal Humidifier tank fits most vertical pianos. However, some vertical pianos have a bottom cavity too shallow to accommodate the standard tank. For those pianos, Dampp-Chaser manufactures a special System called a Backside Vertical 9-Part System that positions the Humidifier assembly in the back of the piano (**Figure 6**). This System fits Steinway upright models, player pianos, Disklaviers, and several other small uprights.

STEP 2. MOISTURE DISTRIBUTION BAFFLE INSTALLATION

Now, with the Humidifier in place you can install the Moisture Distribution Baffle. Attach the baffle under the keybed so that it is centered directly above the Humidifier tank. You may need to use your scissors to make one or more cutouts in the baffle to ensure that it clears any plate struts above it. You will need two pin pegs (**Figure 7**) from the hardware kit. Push them through the baffle and into the keybed about six inches from either end of the baffle (**Figure 8**). The handle from the magnetic 1/4" hex driver (part #20207) is the easiest insertion tool to use. However, a small hammer can also be used to set the pin pegs.

Properly installed, the baffle should not touch the strings nor should it protrude above the bottom panel of the piano. The crease should be up like a roof ridge to distribute the moist air (**Figure 9**).

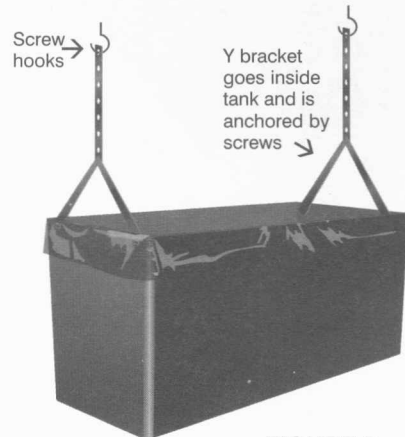

FIGURE 5
Attaching Y brackets to the Tank



FIGURE 7
Pin Peg

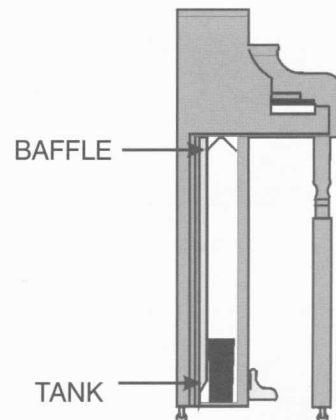

FIGURE 9
Side view of installed baffle

STEP 3. DEHUMIDIFIER INSTALLATION

To help you determine the correct height for the Dehumidifier, you may wish to use the Third Hand Template which is included with your Vertical System. Instructions for its use are printed on the front of the template. Alternatively, use the following method to hang the Dehumidifier:

First, hold the Dehumidifier inside the piano approximately where you think it might need to go, to be sure it clears rods and the plate without touching them. Press the pedals to be sure they don't touch the Dehumidifier when activated. You may need to position the tank differently to avoid this problem.

To determine the height of the Dehumidifier, measure 14" from the floor on the treble end and use chalk to mark a line from front to back on the side of the piano (Figure 10). You will need two pin pegs. Push a pin peg into the chalk line directly above the Humidifier heater bar (this will allow the Dehumidifier to be installed where it is centered over the tank). Measure 14" from the floor of bass end and mount the second pin peg.

Notice that each end of the Dehumidifier extends almost 6 inches. Loosen the two clamp screws that secure the telescoping ends. Notice the holes in the center of the caps at each end of the rod. Pull out the extension (opposite the end with the cord) 4 inches and tighten the screw. Put the pin peg at the treble end into this hole (Figure 11). Now pull out the extension with the cord and install it on the pin peg at the bass end. This allows you to hang the rod. Tighten the extension screw loosely but enough to hold the Dehumidifier in place. Step back and look at the Dehumidifier to make sure that it is level and centered over the Humidifier tank and adjust if necessary. Now

tighten the screw to hold the Dehumidifier firmly in place. (Overtightening this small extension screw may cause stripping of the threads.)

Note, that with either a tank resting on the floor or a suspended tank (Step 1-A, page 4), the Dehumidifier should be located approximately 8 inches above the Humidifier tank. (See the Humidistat installation instructions below.) If you need to protect the action from high humidity, mount a 36-inch, 25-watt Dehumidifier under the keybed and control it with the Humidistat. Be sure the Dehumidifier is mounted under the keybed in a position that does not interfere with the removal of the bottom board. **Do not place a Dehumidifier in the action.**

STEP 4. HUMIDISTAT INSTALLATION

With the Dehumidifier in place, you can now install the Humidistat. It should be noted that the two end vent holes on the top of the Humidistat act as a "chimney" to vent heat from the Humidistat. The holes should not be obstructed in any way in the final installation. Later in the installation, the Water Sensor probes, the Smart Bracket and the Light Panels will be plugged into jack outlets at the bottom of the Humidistat. The Dehumidifier and Humidifier will also be plugged into the Humidistat.

To install the Humidistat, find two C clip Humidistat hangers (Figure 12). Attach the clips to the top of the Humidistat by inserting the rectangular base of the clips into the rectangular holes on either side of the 4 vent slots. Rotate the clips 1/4 turn. You will feel the clips lock into place (Figure 13). Now you are ready to snap the clips onto the Dehumidifier. Carefully squeeze the clips onto the Dehumidifier until they click into place (Figure 14).

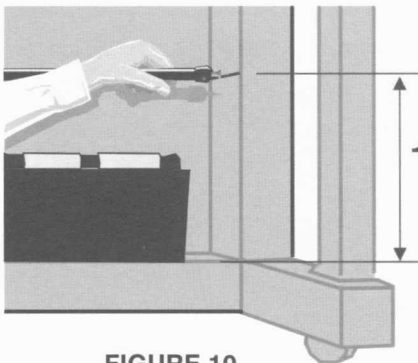

FIGURE 10
Installing Dehumidifier
14" from the floor of the piano

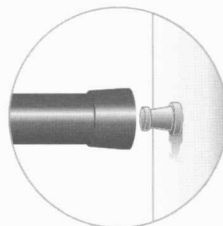

FIGURE 11



FIGURE 12

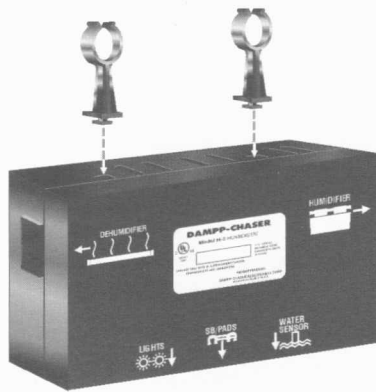
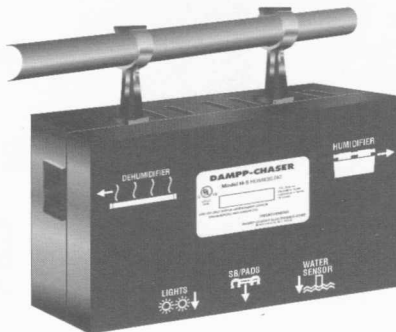

FIGURE 13
Installing clips
onto Humidistat

FIGURE 14
Clipping Humidistat
to Dehumidifier



Ideally, the lower corner of the Humidistat should be positioned 2 inches above the top of the Humidifier tank and 2 inches away from the side of the Humidifier tank (Figure 15). With a suspended tank, the Humidistat should also be positioned approximately 2 inches above and 2-inches from the side of the tank.

Now, plug the Dehumidifier and the Humidifier into the Humidistat. **Make sure you do not put the plugs into the wrong outlets.** The Humidifier plug and Humidistat outlet for the Humidifier are color-coordinated (white) for easy identification (Figure 16). Route the main power cord for the Humidistat out of the piano. First run the 10-foot cord to the treble end. Then run it up beside the action and out the lid (Figure 17). From there the cord goes down to an electrical outlet. With experience you will develop your own technique for bringing the cord

out under the lid. The 1/4" clamps may be used to attach the cord to the inside of the piano.

You may prefer another method of running the power cord out of the piano. If you feel comfortable drilling a hole in the bottom board, you can bring the power cord out through the hole (Figure 18). To provide strain relief for the cord, knot it and secure the knot to an appropriate wood area with one of the 1/4" clamps provided.

From the Humidifier tank, take the white cord, with the telephone jack adaptor, and plug it into the Humidistat outlet marked **WATER SENSOR** (Figure 19). If using the optional Smart Bracket, plug the Smart Bracket's phono jack adaptor into the outlet marked **SB/PADS**. Using wire ties and cable ties, neatly rebundle excess cords for the Dehumidifier, Humidifier, Water Sensor and Smart Bracket.

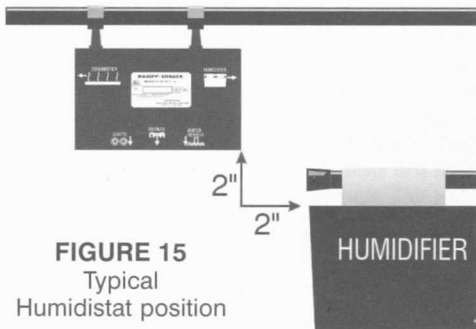

FIGURE 15
Typical
Humidistat position

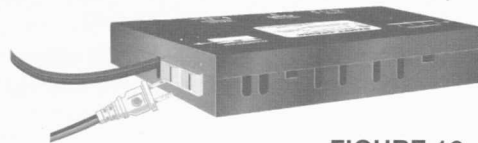

FIGURE 16
White Humidifier Heater Bar plug is color-coded to white Humidistat outlet.

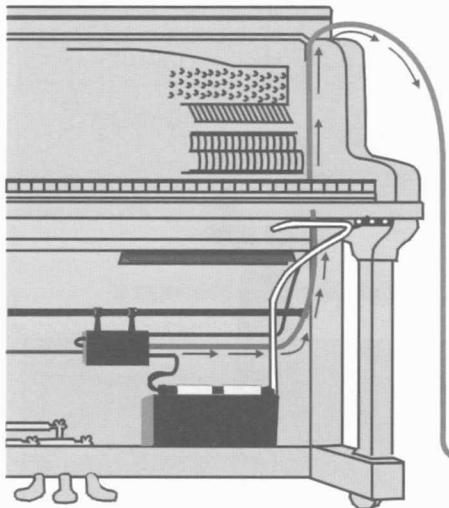

FIGURE 17
Routing the power cord
out of the piano

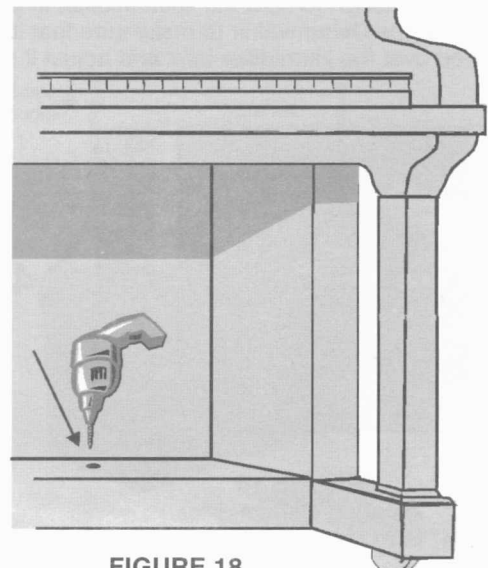

FIGURE 18
Alternate method for running
power cord out of piano

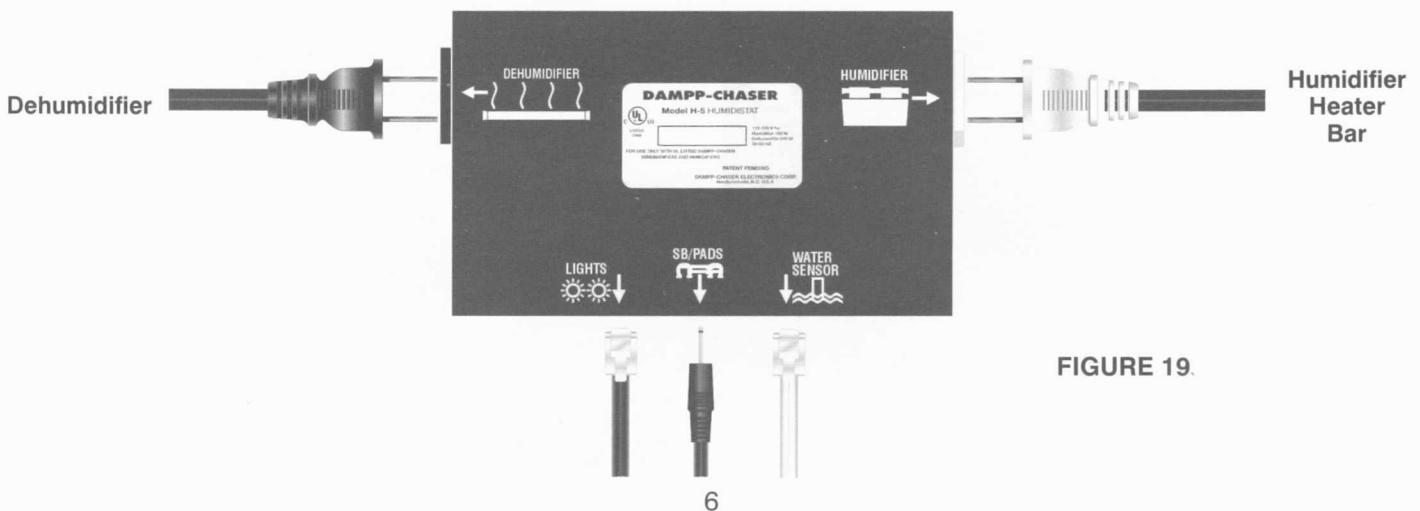

FIGURE 19.

STEP 5. LIGHT PANEL INSTALLATION

The two-light panel (**Figure 20**) features a green light marked **POWER**, to indicate the System has electrical power, and a yellow light marked **WATER**, which blinks when the Humidifier needs water. If the System includes the optional Smart Bracket (SB), there will be a single-light cube with a red light for the SB. The red light, marked **PADS**, will blink when the pads need to be replaced. Connect the two-light panel and single-light cube together (**Figure 20**) by inserting the tongue-latch and two prongs (on the side of the single-light cube) into the corresponding openings on the two-light panel. Insert the metal prongs first while firmly pushing the panels together. **NOTE:** the tongue-latch is slightly bent to create a snug fit between the two panels.

To mount the light panel select (2) 3/4-inch screws and (3) 3/16-inch clamps with (2) 1/2-inch screws. Now, run the light panel cord so that the panel is at an appropriate location under the keyboard. Usually this is at the extreme treble end beside the leg of the piano. Use the two 3/4-inch screws to attach the light panel under the keyboard (**Figure 21**). Take the phone jack adaptor from the light-panel and plug it into the Humidistat outlet marked **LIGHTS**.

Be sure none of the cords/wires touch the Dehumidifier rods, as exposure to heat can damage the cords/wires.

Conceal the cords/wires from the light panel using the 3/16-inch clamps and a wire tie, if necessary.

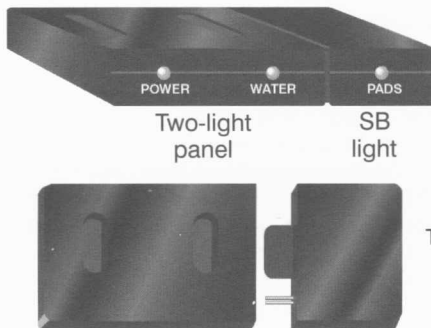

FIGURE 20
Tongue-latch and prongs
insert in openings

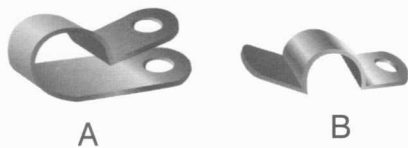

FIGURE 22
Two types of clamps for Watering Tube
(A) standard clamp
(B) half clamp

STEP 6. WATERING TUBE INSTALLATION

The next step is to run the watering tube to the appropriate location. You must be sure the tube will fit over the top of the bottom panel. If the bottom panel pinches the tubing, check to see if there is more space toward the middle of the panel. If it does not fit, use your file to remove enough of the panel corner to allow the tube to go through.

Two types of clamps are provided to anchor the watering tube: (2) 1/2-inch standard clamps and (2) 1/2-inch half clamps (**Figure 22**). Use 1/2-inch screws to mount the half clamps and 1/2-inch screws for the standard clamp.

Figure 23 shows a typical watering tube installation. It's important to curve the tube so it can be pulled out freely for watering. To make this possible, the open side of the half clamps should face the front of the piano. Serrated washers bite into the wood and keep the half clamps in the proper position. The end of the watering tube should extend beyond the first half clamp by 1 to 2 inches. Position the standard clamps to prevent sagging of the tube in locations that do not interfere with replacement of the bottom panel.

After the Piano Life Saver System is completely installed, plug the Humidistat into a non-switchable wall outlet where it cannot be turned off and therefore will be fully energized at all times.

Continued on page 8

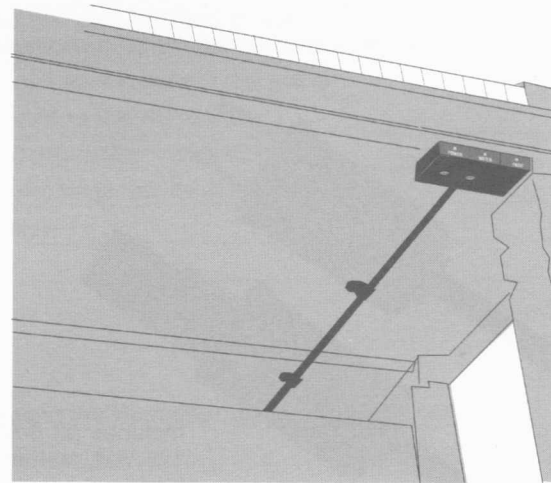

FIGURE 21
Placement of Light Panel

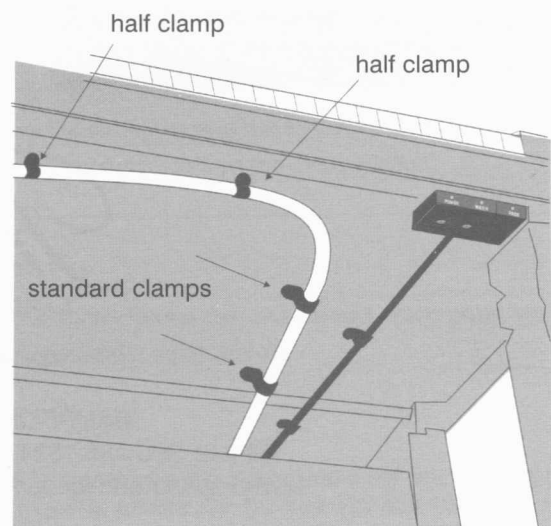

FIGURE 23
Placement of Watering Tube clamps

Notice the new Fused Plug on the Humidistat Power Cord in Figure 24. In the event of damage to the cord, or a direct lightning strike, the fuse in the plug will “blow out” and prevent the flow of electricity through the power cord, thus preventing any further damage. The plug contains two 5-AMP, 125-Volt glass fuses. If the green POWER light is not on, advise the piano owner to unplug the System and inspect the cord for damage. If there is no damage, remove the fuse from the brass clips inside the plug and replace it with the spare fuse in the plug. If the cord is damaged, the Humidistat should not be plugged into an electrical outlet. Call our technical support number for instructions, (800) 438-1524 or (828) 692-8271.

Only 5-AMP, 125-Volt, 5 mm x 20 mm, fast-acting, glass fuses should be used in the plug. Never use a fuse with greater amperage than 5 AMPS. These fuses are readily available at electronics stores such as Radio Shack. In the event you cannot find the fuses, Damp-Chaser has a supply.

STEP 7. WATERING THE SYSTEM

The final step is to fill the Humidifier with water. **FILL THE HUMIDIFIER WITH THE WATERING CAN FILLED TO THE FULL CAN MARK.** Instruct the piano owner to add a watering can filled to the full can mark whenever the yellow low water warning light blinks. Also instruct the piano owner to add one capful of Humidifier Treatment to each full watering can. Humidifier Treatment inhibits mildew in both the watering tube and the Humidifier tank and increases the life of Humidifier pads.

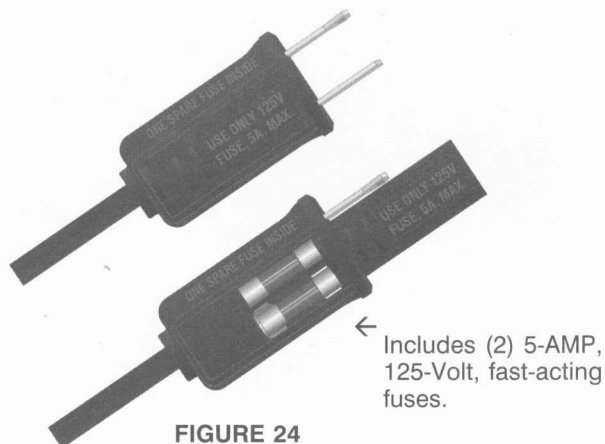

FIGURE 24

For several years we have included fused plugs on all Systems which protect pianos in the United Kingdom and “blown” plug fuses are a rare occurrence.

Warning: Add only the Damp-Chaser brand of Humidifier Treatment to the Humidifier water. Other brands of humidifier treatment may contain acids which may corrode strings and metal parts in the piano. The use of other humidifier treatment preparations will void the warranty of the Piano Life Saver System and may void the warranty of the piano manufacturer.

If tap water comes from a well or is “hard” water, meaning containing significant minerals, we recommend using distilled water. If distilled water is used, add Humidifier Treatment (according to the label instructions) to insure there are adequate electrolytes in the Humidifier to support operation of the low water warning light. Without sufficient electrolytes, the light will blink continuously, even when the tank is full. **Do not put salt in the Humidifier, as it is corrosive.**

To fill the Humidifier tank, simply reach under the keyboard, pull the tubing out of the half clamps, connect the spout inside the tube, raise the watering can, and add water. After the humidifier is filled, the watering can (which is still connected to the watering tube) should be lowered below the bottom of the rim so that any water remaining in the tube is drained into the watering can. Then, disconnect the watering can from the tube and push the tube back into the half clamps. The System is designed so siphoning will not occur. This completes the installation of the System.

Humidifier Maintenance: To ensure a properly functioning Humidifier, the pads should be changed at least twice each year. This applies whether a Smart Bracket is used or not. Change them during the fall service of the piano and then again in the spring. Replacement pads can be obtained from Damp-Chaser or from any Damp-Chaser distributor. Clean the Humidifier once yearly by changing the liner. Be sure that the watering tube is inside the liner when it is replaced. The holes in the new liner may be enlarged with a pair of scissors to make installation easier.

Smart Bracket Maintenance: If the System includes the optional Smart Bracket, the sensor wires operate more effectively if the wires are kept free from corrosion and minerals. During pad changing, remove the Bracket from the heater bar. Remove the mineral residue on the wires by scraping with the dull edge of a knife held perpendicular to the wire. Alternatively, it may be simpler to bring a new SB to replace the old one. Replacement SB's are available from your Damp-Chaser distributor.

DAMPP-CHASER'S TECHNICAL SERVICE DEPARTMENT IS AVAILABLE TO ANSWER ALL INSTALLATION QUESTIONS AT 800-438-1524.



DAMPP-CHASER CORPORATION
 Toll-free: 800-438-1524 • 828-692-8271 • Fax: 828-692-8272
 www.PianoLifeSaver.com • e-mail: piano@damp-chaser.com
 Post Office Box 1610
 Hendersonville, North Carolina 28793